

Audi > B5 Platform > 1996 - 2002

Body Exterior

64 - Glass, Window regulators

Undamaged side window (Avant), removing

- C/D pillar trim removed
- Side trim removed
- On vehicles with glass breakage sensors, harness connector must be disconnected at window to be removed and the window-side wire must be secured on window (towards center) using adhesive tape.

CAUTION!

If harness connectors are not disconnected, the wires will be cut during the cutting process and the window will be destroyed.

- Drill off rivet heads at C-pillar and knock out rivet shaft.
- Remove C-pillar trim.

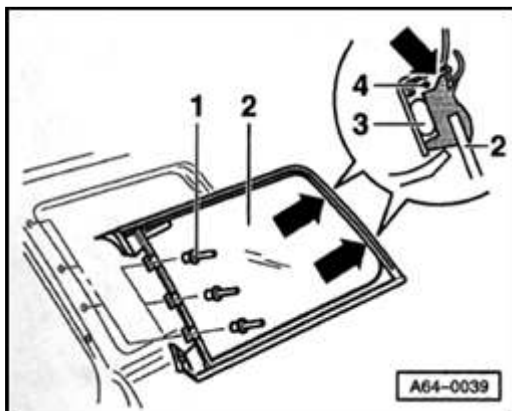

- Drill off rivet heads -1- and knock out rivet shafts.

On vehicles with anodized trim strip, it should be removed => page [64-30](#).

- Using handle -1-, stick needle -2- through adhesive bead.
- Guide needle as close to glass as possible.

- Remove handle and thread cutting cord through eye of needle.
- Pull end of cutting cord -A- into interior (use pliers and gloves).

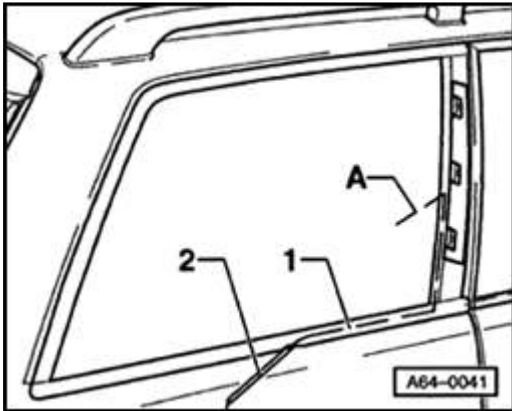

- Pull cutting cord -1- and small tube -2- in under adhesive trim.

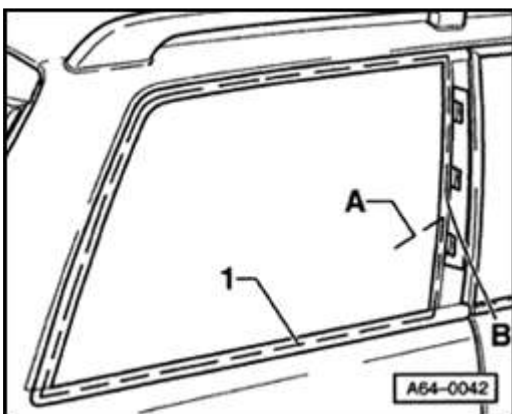

- Place cutting cord -1- completely around glass.
- Fasten cutting cord ends -B- onto lock bracket => page [64-34](#).

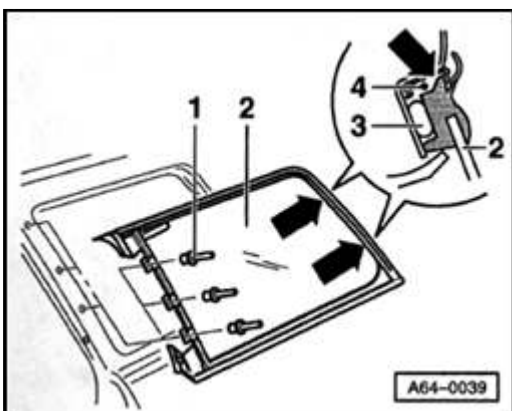

- Pull cutting cord under retaining tabs at D-pillar (arrows) using needle from special tool VAG1755.

CAUTION!

The cord -4- must be placed below both retaining tabs (arrows) and before the adhesive bead in the area of the D-pillar.

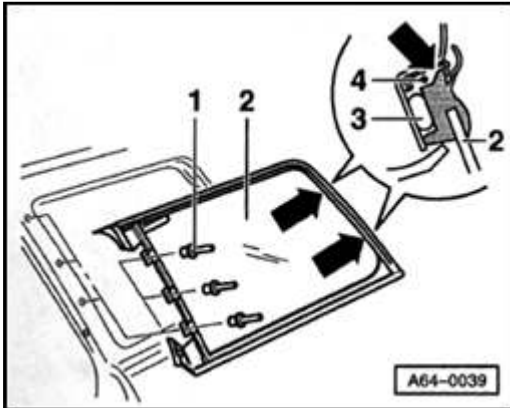

- Pull cutting cord and needle from VAG1755 under retaining tabs (arrows).

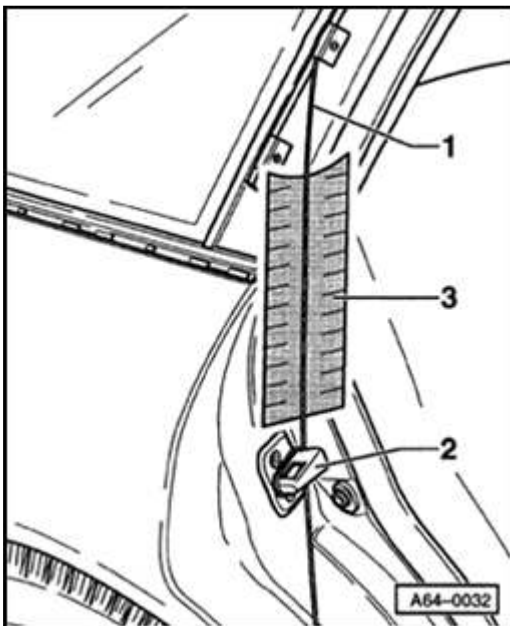

- Fasten outer cutting cord end -1- to lock bracket -2- (route cutting cord using fabric reinforced adhesive tape -3-).

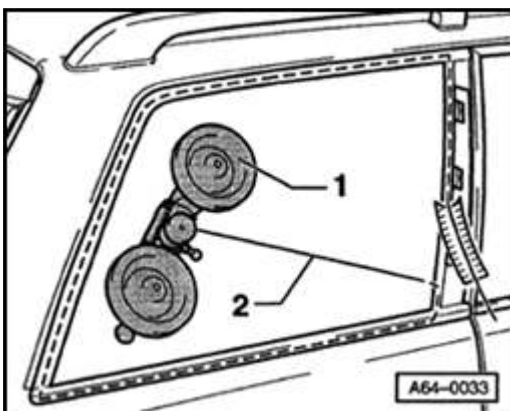

- Attach spooling tool as shown together with cutting cord.
- Cut first area at C-pillar and window bottom.

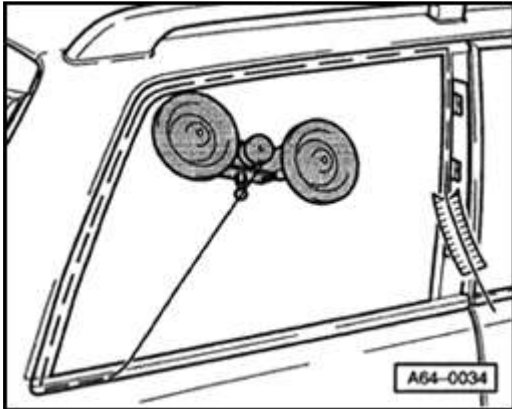

- Move spooling tool and continue cutting.
- While cutting, press cutting cord in direction of D-pillar.

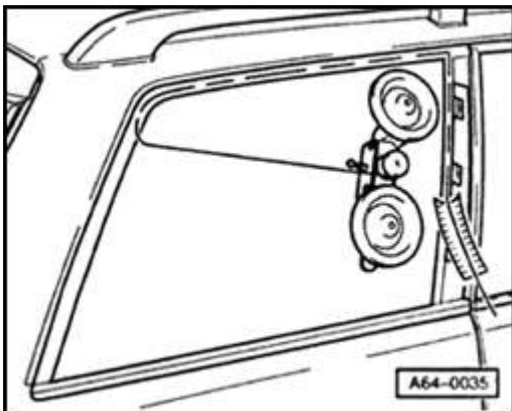

- Move spooling tool as shown and continue cutting.
- While cutting, press cutting cord upward.

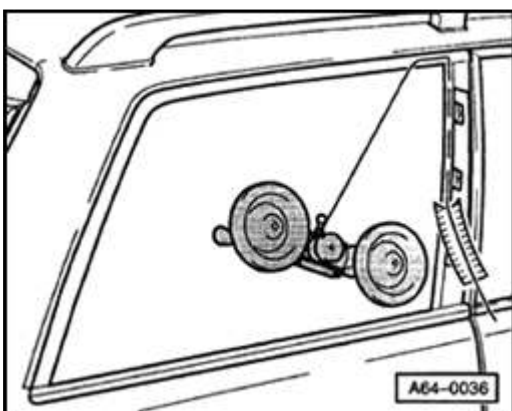

- Move spooling tool downward and cut side glass out completely.

- While cutting, press cutting cord in direction of C-pillar.
- Remove side glass using double suction cups.